

## 5.0T Fluid Coupling Diesel Forklift

**Capacity : 5000 kg @ 600 mm L.C.**



### ENGINE

Bharat Stage III compliant four cylinder turbo charged diesel engine conforming to IS: 10000 (1980) is used. Twin element dry type Air Filter with restriction indicator is provided. Engine is equipped with dual fuel filter, mud filter and lubrication oil filter. Fuel tank capacity is 70 liters.

**Bharat Stage III compliant engines are supplied with our forklift trucks to comply with the norms of Emission Standards instituted by Government of India. This will reduce the air pollutants. This will also enhance the fuel savings and engine performance.**

The engine cooling system with cross flow radiator and a pusher type fan is standard. A pressurized sealed cooling system with coolant recovery reservoir can be provided as an optional feature.

12 volts electrical system with starter motor, alternator and battery is standard.

### FLUID COUPLING TRANSMISSION (FC)

The fluid coupling drive between engine and clutch provides cushioned drive without metal to metal contact. Starting slip takes place in coupling, greatly prolonging clutch life. Two speeds forward and reverse provide the full range of torque requirements. The floor mounted gear shifter lever eliminates complicated linkages and wear points. The one piece axle housing employs hypoid ring gear and pinion. A 4-pinion differential transmits power smoothly through the involute splined, full floating drive shafts. The rugged pinion design withstands the stresses of repeated tight turns. All gears operate in a common oil bath.

**“Available with Pneumatic brakes also as an Option”**

**MAX**

**Reliability  
Performance  
Productivity**



## BRAKES

Service brakes are heavy duty truck type drum brakes that are self-energizing and self-adjusting. conforming to IS: 9701 (2001). Hand operated parking brake is provided.

## MAST, CARRIAGE & FORKS

An excellent design supported by superior welding process, ensures highly durable and dependable high MFH visibility masts, High Visibility mast is standard. Optional Triplex mast variants are available for a variety of applications including container stuffing / de-stuffing. High visibility carriage with improved visibility is standard.

## STEER AXLE

The axle is fabricated from steel plates for durability and strength. The axle is supported in the frame by using hardened steel bushings for providing the required articulation. The integrated balanced power cylinder is well protected inside the axle body. The axle assembly is made by using plain pin joints for ease of maintenance.

## FRAME AND CANOPY

The frame is designed using computer aided modeling and optimized by finite element analysis techniques. It is fabricated from heavy steel plates using a flux cored arc welding process, ensuring excellent rigidity and strength. An elegant canopy integrated with the frame body provides a safe enclosure for operator conforming to IS: 7621 (2000).

## HYDRAULIC SYSTEM

Hydraulic system consists of reservoir, pump, directional control valves, cylinders and full flow filtration system with bypass protection, suction strainer and 25 micron replaceable return line filter. Pressure relief, tilt lock and flow control valves are provided for safety, Tank capacity 70 liters.

## INSTRUMENTATION AND CONTROLS

Instrument panel consisting of fuel, oil pressure, water temperature, ammeter and engine hour meter gauges is ergonomically located for operator's view. All the gauges are illuminated for night driving. All control levers, switches and pedals are located ergonomically enhancing operator comfort.

## AFTER SALES SERVICE AND TECHNICAL SUPPORT

Prompt After Sales Service and technical support is ensured through a nation wide network of more than 100 Voltas Touch Points with strong dealer network. Factory trained engineers at locations support speedy resolution of field problems. Training programs are offered all around the year at our Technical Training Centre at Pune.

## PARTS SUPPORT

Our Central Parts Ware house located at Pune caters to timely supply of parts with additional stock maintained at more than 100 Voltas Touch Points. Emergency requirements are processed through special channel to ensure supply latest within 48 hrs to restore breakdown machines with least down time.

# DVX 506 FC

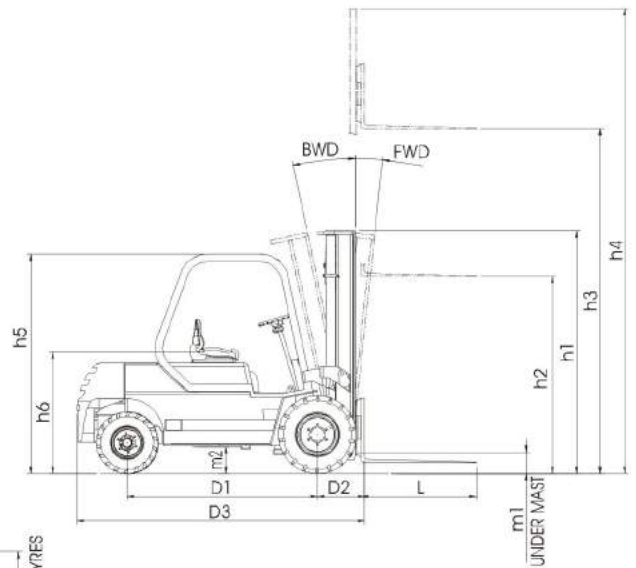
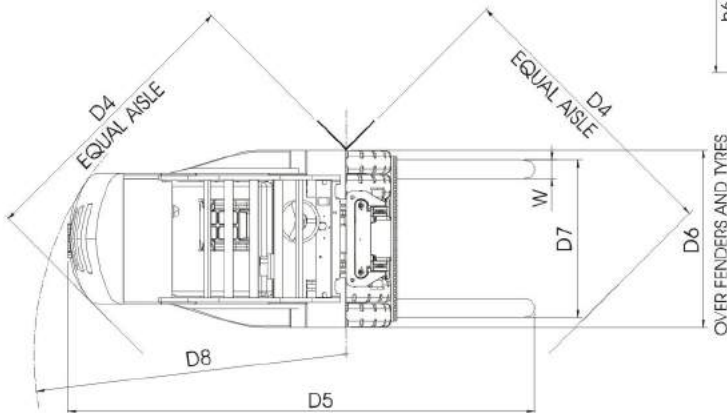
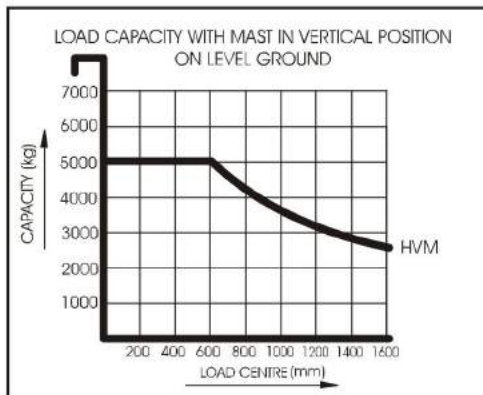

Above diagram is for DVX 506FC only

## MAST CONFIGURATIONS

TYPE OF MAST	MAST MODEL	OAH (mm) h1	FFH (mm) h2	MFH (mm) h3	OAH at MFH with LBR, h4	TILT ANGLE (Deg)		CAPACITY AT MFH at 600 mm LC
						FWD	BWD	
2-Stage	HVM	2530	NIL	3660	5110	6	10	5000*
3-Stage	HVT 2100	2100	1310	4200	5640	6	6	4250*

OAH : Overall Mast Height    FFH : Free Fork Height    MFH : Max Fork Height    FWD : Forward    BWD : Backward

\* Capacity shall derate by 400kg with sideshifter

## SPECIFICATIONS

					KION INDIA	
GENERAL	1	MANUFACTURER				
	2	MODEL			DVX 506 FC	
	3	CAPACITY	LIFTING LOAD		KG	5000
	4	LOAD CENTER	FROM FACE OF THE FORK		MM	600
	5	POWER UNIT	ENGINE TYPE			DIESEL
	6	TYRES	PNEUMATIC (PD), CUSHION (BCD)			PD- STD, BCD - OPTION
DIMENSIONS	7	LIFT HEIGHT	MAX FORK HEIGHT	h3	MM	3660
	8	STANDARD MAST	STD FREE LIFT	h2	MM	NIL
	9	FORK CATTIAGE	ISO CLASS			4A
	10	FORK	THICKNESS (thk) X WIDTH(W) X LENGTH(L)		MM	65 X 150 X 1220
	11	FORK SPREAD	MIN / MAX	D7	MM	330 - 1510
	12	TILT ANGLE WITH HVM	FORWARD / BACKWARD		DEG	6 / 10
	13	OVERALL DIMENSIONS WITH STD HVM MAST	LENGTH TO FACE OF FORKS	D3	MM	3250
	14		OVERALL WIDTH	D6	MM	1815
	15		HEIGHT WITH COLLAPSED MAST	h1	MM	2530
	16		HEIGHT WITH EXTENDED MAST	h4	MM	5110
	17		HEIGHT OF CANOPY GUARD	h5	MM	2375 / 2150
	18		SEAT HEIGHT	h6	MM	1275
	19	TURNING RADIUS		D8	MM	3000
20	FRONT OVERHANG		D2	MM	510	
21	AISLE WIDTH	EQUAL AISLE	D4	MM	2658	
22		AISLE RIGHT ANGLE	D5	MM	4940	
PERFORMANCE	23	DPEEDS WITH STD HVM	TRAVEL - LADEN / UNLADEN		KMPH	18 / 19
	24		LIFTING - LADEN / UNLADEN		MM/S	400 / 500
	25		LOWERING - LADEN / UNLADEN		MM/S	450 / 350
	26	DRAWBAR PULL	LADEN / UNLADEN (5 MIN)		N	12900 / 10900
	27	GRADABILITY**	LADEN / UNLADEN		%	15 / 17
28	STEERING TYPE	POWER STEERING			HYDROSTATIC	
FRAME & TYRES	29	WEIGHT WITH STD HVM	SERVICE WEIGHT		KG	6720
	30	AXLE LOADS WITH STD HVM	LADEN - FRONT / REAR		KG	10260 / 1010
	31		UNLADEN - FRONT / REAR		KG	2800 / 3450
	32	TYRES	No - FRONT / REAR		No	4 / 2
	33		SIZE - FRONT		MM	7.00 X 12 - 16 PR
	34		SIZE - REAR		MM	7.00 X 12 - 16PR
	35	WHEEL BASE		D1	MM	2030
	36	TRACK	FRONT / REAR		MM	1390 / 950
	37	GROUND CLEARANCE	UNDER MAST	m1	MM	150
	38		UNDER FRAME	m2	MM	200
	39	SERVICE BRAKE				HYDRAULIC
40	PARKING BRAKE				MECHANICAL	
DRIVE	41	ENGINE	MANUFACTURER / MODEL			SIMPSON TSJ 436
	42		ENGINE RATING		HP	75
	43		RATED RPM		RPM	2200
	44		RATED TORQUE		KGM@RPM	29.5@1500
	45		NUMBER OF CYLINDERS		No/CC	4
	46	GEAR BOX	MAKE / MODEL			VOLTAS
	47		TRANSMISSION			FLUID COUPLING
	48		No. OF SPEEDS		FWD/REV	2 / 2
	49		GEAR SHIFT			MECHANICAL

\*\* GRADABILITY WITH CUSHION TYRES IS LOWER BY 2% OVER THE ABOVE FIGURES.

SAFETY : TRUCK CONFORMS TO STABILITY REQUIREMENT AS PER "BIS" & "ISO" STANDARDS

ALL SPECIFICATIONS ARE SUBJECT TO TOLERANCE OF +/- 12% APART FROM THOSE GOVERNED BY BIS

DUE TO CONTINUOUS DESIGN IMPROVEMENTS THE DIMENSIONS ARE SUBJECT TO CHANGE WITHOUT NOTICE.

# 100+ CUSTOMER TOUCH POINTS



## KION India Private Ltd.

**Plant :** 5/4 Chandan Nagar, Pune-Nagar Road,  
Pune - 411014, Maharashtra, India

**Enquiries :** [in.enquiries@kiongroup.com](mailto:in.enquiries@kiongroup.com)

**Contact :** 020 - 67342-194 / 154 / 193 / 208 / 130



F.MKT.KION.302.140.00

Feb. 2018 / 00 - Qty.: 2000

**Sales Toll Free No. : 1800 270 9982**